



Guardian Economy Motor Support

The head bracket, a combination of aluminum and delrin, fits snugly to the contours of the motor. A locking Delrin strap mount over-the-roller mount for easy attachment to the trailer. (Bolt on). Adjust 26-3/4" – 38-3/4".

ORDER NO.	PRICE
SPM 1780236	\$58.75



Transom Saver

Constructed entirely of aluminum, the Guardian is 100% rust-proof. The Guardian is designed both to protect the leading edge of your motors lower unit as well as the transom of your boat.

No. 1780227 (bolt-on)
Adjust 26-3/4" – 38-1/4".

ORDER NO.	PRICE
SPM 1780227	\$74.17



Adjustable Bolt-On Transom Saver with Roller Bracket

This transom saver is constructed of high tensile anodized aluminum. It features a pivoting foot to fit most outboard engines and includes both the roller adapter and bolt on bracket for your choice of mounting options.

ORDER NO.	DESCRIPTION	PRICE
DRS TS2	29-51"	\$43.80



Trailer Clips I/O Motor Support

These trailering clips provide an inexpensive way to protect stern drive units while trailering or storing. They relieve the stress on the tilt and trim system by transferring the stern drive weight from the hydraulic cylinders to the transom bracket. These clips will prevent damage from weight surges during trailering. Fits all Mercruiser Alpha 1, Alpha 1 Generation II, Bravo 1, Bravo II, Bravo III, and Blackhawk Stern Drives. Units may be trimmed to for shorter rams.

ORDER NO.	PRICE
THM TC1DP	\$23.93

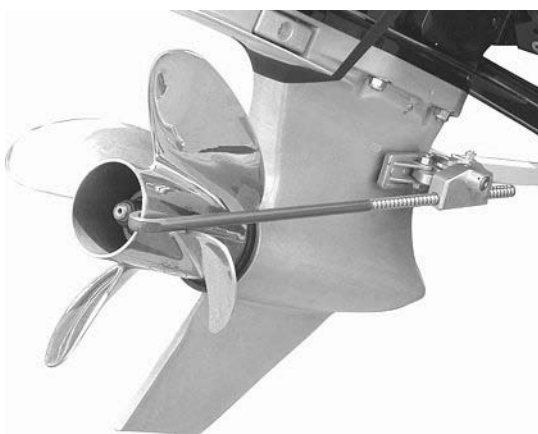

T-Rex® Transom Saver with Prop Lock

Protect your boat transom and deter theft of your propeller and transom saver with the T-Rex®. This worldwide product utilizes the traditional design of a transom saver while incorporating a prop lock. T-Rex® expands from 29"-51" covering more applications than other transom savers.

ORDER NO.	PRICE
DRS TR1	\$66.67



Does not "tie" the boat's outboard to the trailer, which in some cases can cause "trailer shock" when the boat and trailer get out-of-sync. This is a small compact unit that totally locks the outboard in the forward position without tying it to the trailer. And its small size makes it easy to store in your boot when not in use. Black powder coated finish.

ORDER NO.	DESCRIPTION	PRICE
ATT 10108	Fits Mercury engines 75hp-200hp EFI, 135 OptiMax, 150 OptiMax, 175 OptiMax	\$104.50
ATT 10309	Fits OMC/Bombardier motors from 1989 to present	\$104.25



- Adjustment from 30" - 60"
- Unique angle adjustment (patent pending) from 0 degrees to 36 degrees with 12 degree increments
- Our innovative design will fit any trailer
- Heavy-duty rubber extrusions to prevent scratching on the lower unit
- Black powder coated steel



ORDER NO.	PRICE
ATT 460ADJ	\$85.25